

SE



MATERIALS

Head:
Aluminium alloy

Spin-on cartridge:
Steel

Bypass valve:
Polyamide

Seals:
NBR Nitrile
(FKM - on request fluoroelastomer)

Indicator housing:
Brass

PRESSURE (ISO 10771-1:2002)

Max working:
1,2 MPa (12 bar)

Test:
1,5 MPa (15 bar)

Bursting:
2,5 MPa (25 bar)

Collapse, differential
for the filter element (ISO 2941):
400 kPa (4 bar)

BYPASS VALVE

Setting:
30 kPa (0,30 bar) \pm 10%

WORKING TEMPERATURE

From -25° to +110° C

COMPATIBILITY (ISO 2943)

Full with fluids: HH-HL-HM-HV-HTG
(according to ISO 6743/4)
For fluids different than the above mentioned, please contact our Sales Department.

APPLICATION EXAMPLE



FSE 1+ & FSE 2+

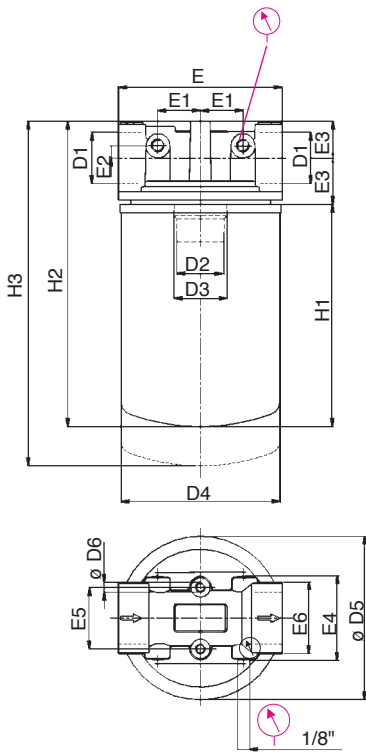

FSE 3+

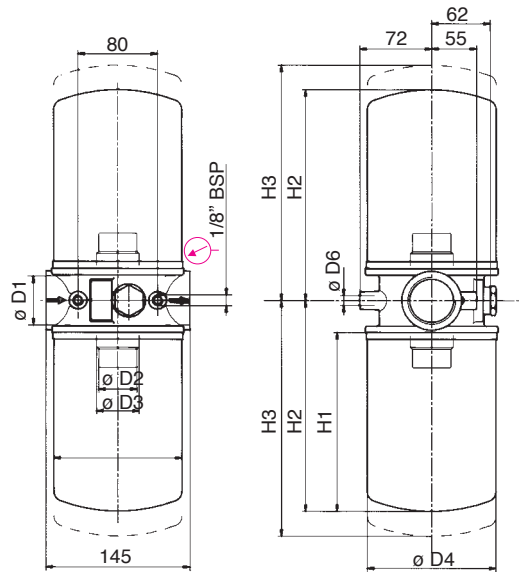

FSE 4+

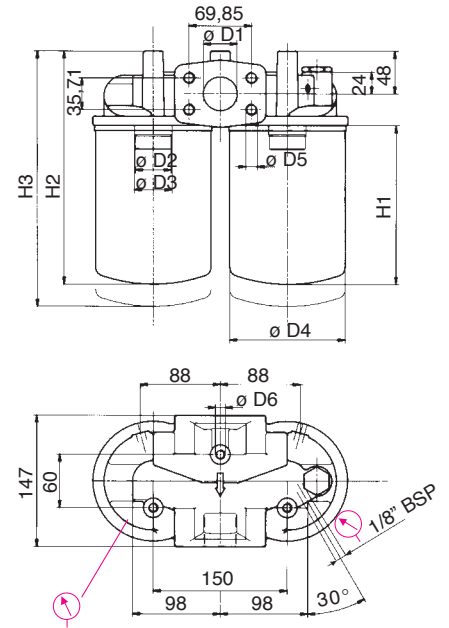

FILTER HOUSING

	D1	D2	D3	D4	D5	D6	E	E1	E2	E3	E4	E5	E6	H1	H2	H3	kg
FSE11	3/4"	3/4" BSP	-	96	96	M8	95	20,5	7	20	49	38	37	145	188	208	1,2
FSE12	3/4"	3/4" BSP	-	96	96	M8	95	20,5	7	20	49	38	37	191	234	254	1,5
FSE21	1" 1/4	1" 1/2 16-UN	1" 1/4 BSP	129	134	M8	133	35	10	30	64	50	57	181	248	278	1,9
FSE31	1" 1/2	1" 1/2 16-UN	1" 1/4 BSP	129	-	M10	-	-	-	-	-	-	-	181	216	246	3,6
FSE41	1" 1/2	1" 1/2 16-UN	1" 1/4 BSP	129	M12	M10	-	-	-	-	-	-	-	181	269	299	4,8
FSE22	1" 1/4	1" 1/2 16-UN	1" 1/4 BSP	129	134	M8	133	35	10	30	64	50	57	226	293	323	2,0
FSE32	1" 1/2	1" 1/2 16-UN	1" 1/4 BSP	129	-	M10	-	-	-	-	-	-	-	226	261	291	3,8
FSE42	1" 1/2	1" 1/2 16-UN	1" 1/4 BSP	129	M12	M10	-	-	-	-	-	-	-	226	314	344	5,0

TYPE											
F = FILTER COMPLETE		F	F	F	F	F	F	F	F		
B = FILTER HOUSING		B	B	B	B	B	B	B	B	ELEMENT E	
S	E									FAMILY SIZE & LENGTH S E	
FAMILY NOMINAL SIZE & LENGTH		11	12	21	22	31	32	41	42		
PORT TYPE											
B = BSP thread		B	B	B	B	B	B	B	B		
F = SAE flange 3000 psi, metric screws		-	-	-	-	-	-	F	F		
PORT SIZE (quote "D1")											
06 = 3/4		06	06	-	-	-	-	-	-		
10 = 1" 1/4		-	-	10	10	-	-	-	-		
12 = 1" 1/2		-	-	-	-	12	12	12	12		
BYPASS VALVE											
W = without		W	W	W	W	W	W	W	W		
A = 30 kPa (0,30 bar)		A	A	A	A	A	A	A	A		
SEALS										SEALS	
N = NBR Nitrile		N	N	N	N	N	N	N	N	N = NBR	
F = FKM Fluoroelastomer		F	F	F	F	F	F	F	F	F = FKM	
FILTER MEDIA										FILTER MEDIA	
CC = cellulose 10µm β>2		CC	CC	CC	CC	CC	CC	CC	CC	CC = cell. 10µm	
CD = cellulose 25µm β>2		CD	CD	CD	CD	CD	CD	CD	CD	CD = cell. 25µm	
ME = metal wire mesh 60µm		ME	ME	ME	ME	ME	ME	ME	ME	ME = w. mesh 60µm	
MF = metal wire mesh 90µm		MF	MF	MF	MF	MF	MF	MF	MF	MF = w. mesh 90µm	
CLOGGING INDICATOR											
06 = 1/8" seat, plugged		06	06	06	06	06	06	06	06		
10 = vacuum gauge, bottom connection		10	10	10	10	10	10	10	10		
91 = SPDT, vacuum switch		91	91	91	91	91	91	91	91		
X	X	ACCESSORIES									
XX = no accessory available		XX	XX	XX	XX	XX	XX	XX	XX		

NOTE
ESE31+++ = nr. 2 x ESE21+++
ESE32+++ = nr. 2 x ESE22+++
ESE41+++ = nr. 2 x ESE21+++
ESE42+++ = nr. 2 x ESE22+++

FILTER ELEMENT

	A	B	C	kg	Area (cm ²)	
					Media M+	Media C+
ESE11	96,5	3/4" BSP	146	0,70	980	3.305
ESE12	96,5	3/4" BSP	191	0,80	1.390	4.745
ESE21	129	1" 1/4 BSP	181	1,20	1.940	5.560
ESE22	129	1" 1/4 BSP	226	1,40	2.570	7.360

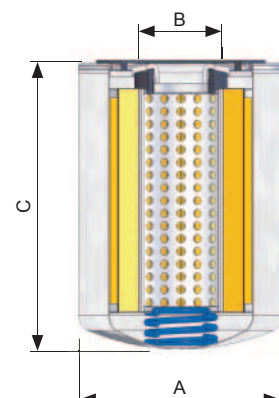

FLUID SPEED

when selecting the filter size, we suggest to consider also the max recommended fluid speed (in suction lines normally $0,1 < v < 1$ m/s)

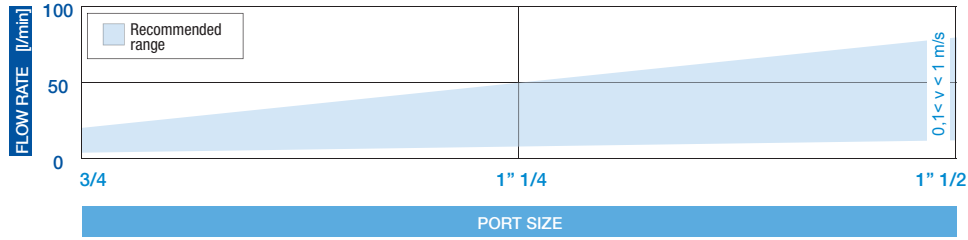

PRESSURE DROP CURVES (Δp)

The "Assembly Pressure Drop (Δp)" is obtained by adding the pressure drop values of the Filter Housing and of the Clean Filter Element corresponding to the considered Flow Rate and it must be lower than 3 kPa (0,03 bar).

FILTER HOUSING PRESSURE DROP
(mainly depending on the port size)

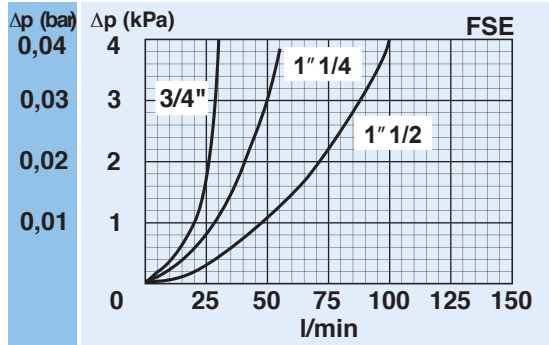

CLEAN FILTER ELEMENT PRESSURE DROP WITH C+ AND M+ MEDIA
(depending both on the internal diameter of the element and on the filter media)

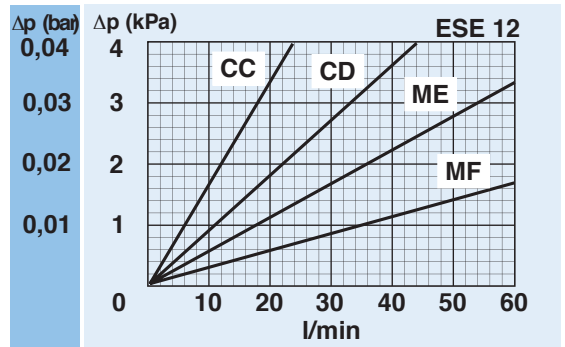
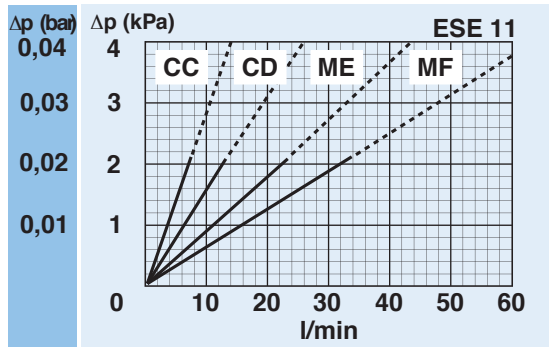

FSE3+ and FSE4+ filters use double element canisters. The Assembly Pressure Drop is therefore determined by adding the Housing Pressure Drop at the real flow rate and half the pressure drop of the ESE2+ element.
E.g. The pressure drop of a complete FSE31----FC--- filter at a 60 l/min flow rate is obtained by adding the Housing Pressure Drop and half the ESE21NFC element pressure drop at 60 l/min.

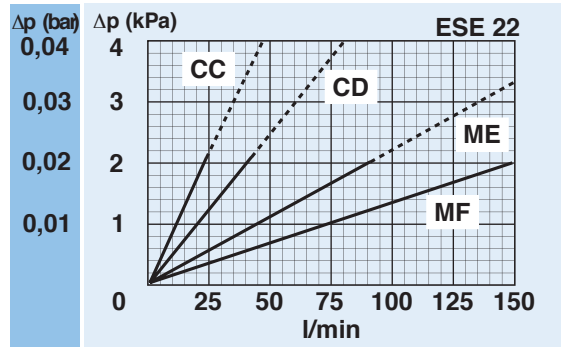
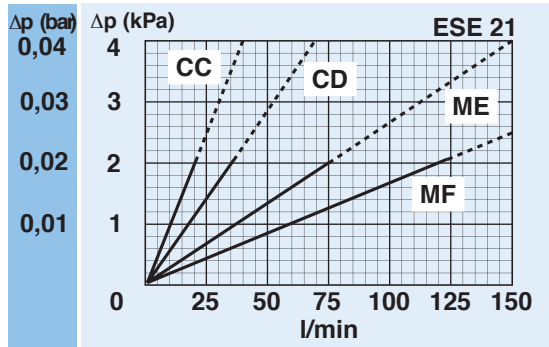

BYPASS VALVE PRESSURE DROP

When selecting the filter size, these curves must be taken into account if it is foreseen that any flow peak is to be absorbed by the bypass valve, it also must be of proper configuration to avoid pressure peaks. The valve pressure drop is directly proportional to fluid specific gravity.

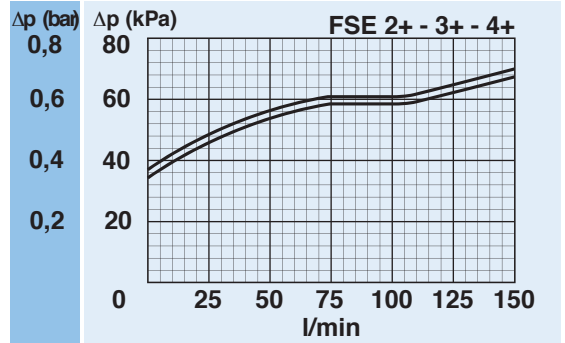
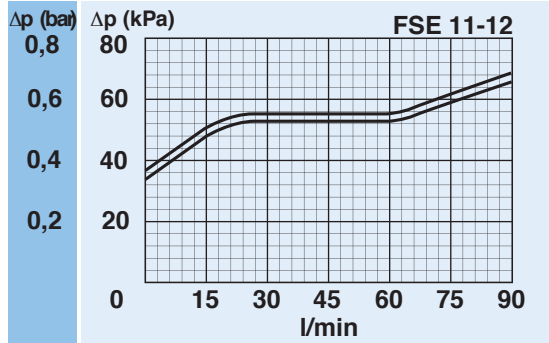

N.B. All the curves have been obtained with mineral oil having a kinematic viscosity 30 cSt and specific gravity 0,9 kg/dm³; for fluids with different features, please consider the factors described in the first part of this catalogue. All the curves are obtained from test done at the UFI HYDRAULIC DIVISION Laboratory, according to the specification ISO 3968:2005. In case of discrepancy, please check the contamination level, viscosity and features of the fluid in use.

