

HTO

CILINDRO TUFFANTE STANDARD
STANDARD PLUNGER CYLINDER

Series M250

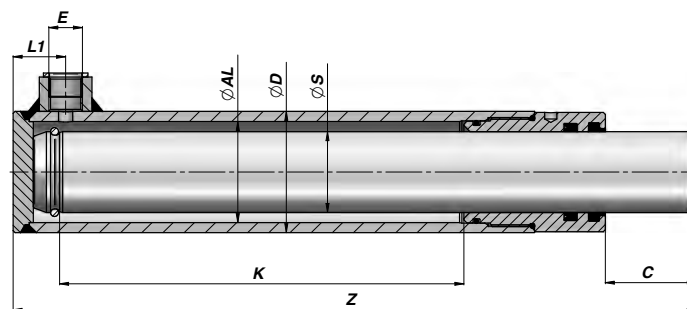
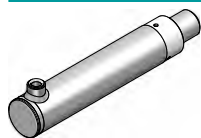

Codice Code	K	Z	kg	E BSP	L1	C
ØD 50 ØAL 40 ØS 30						
HT02300200	200	326	3,67	3/8"	23	40
HT02300250	250	376	4,22			
HT02300300	300	426	4,78			
HT02300350	350	476	5,33			
HT02300400	400	526	5,89			
HT02300500	500	626	7,00			
ØD 60 ØAL 50 ØS 40						
HT03400200	200	338	5,67	3/8"	26	45
HT03400300	300	438	7,34			
HT03400400	400	538	9,00			
HT03400500	500	638	10,67			
HT03400600	600	738	12,35			
ØD 70 ØAL 60 ØS 50						
HT04500300	300	450	10,60	3/8"	30	50
HT04500400	400	550	12,94			
HT04500500	500	650	15,28			
HT04500600	600	750	17,62			

MATERIALE TUBO: ACCIAIO St 52.3 DIN 2393 ISO H9
TUBE MATERIAL : STEEL St 52.3 DIN 2393 ISO H9

MATERIALE ASTA: ACCIAIO UNI C45 SAE 1045 CROMO 25 µm ±5 Rating 9 / 200h ISO 10289 - 1999/ISO 9227-NSS
ROD MATERIAL : STEEL UNI C45 SAE 1045 CHROME 25 µm ±5 Rating 9 / 200h ISO 10289 - 1999/ISO 9227-NSS

CARATTERISTICHE TECNICHE : VEDI PAGINA 40 - TECHNICAL SPECIFICATIONS : SEE PAGE 40