

HM5

CILINDRO DOPPIO EFFETTO STANDARD CON ATTACCHI
DOUBLE ACTING CYLINDER WITH ENDS

Series M250

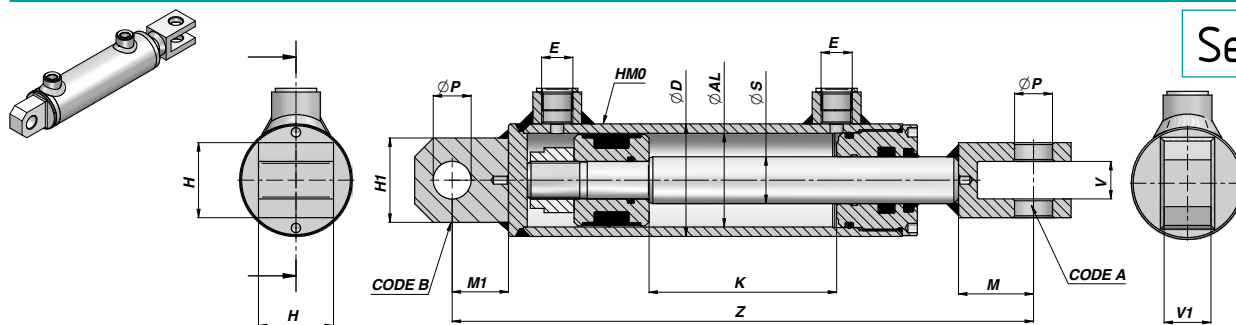

Codice Code	K	Z	kg	E BSP	ØP	H	V	M	H1	V1	M1	Code A	Code B	Codice Code	K	Z	kg
ØD 42 ØAL 32 ØS 20																	
HM5032200050	50	214	1,75														
HM5032200100	100	264	2,10														
HM5032200150	150	314	2,45														
HM5032200200	200	364	2,80														
HM5032200250	250	414	3,15														
HM5032200300	300	464	3,50														
HM5032200400	400	564	4,20														
HM5032200500	500	664	4,90														
ØD 50 ØAL 40 ØS 20														ØD 50 ØAL 40 ØS 25			
HM51200100	100	289	2,77											HM51250100	100	289	2,94
HM51200150	150	339	3,16											HM51250150	150	339	3,40
HM51200200	200	389	3,56											HM51250200	200	389	3,87
HM51200250	250	439	3,97											HM51250250	250	439	4,33
HM51200300	300	489	4,36											HM51250300	300	489	4,81
HM51200350	350	539	4,77											HM51250350	350	539	5,27
HM51200400	400	589	5,16											HM51250400	400	589	5,74
HM51200450	450	639	5,57											HM51250450	450	639	6,22
HM51200500	500	689	5,97											HM51250500	500	689	6,68
														HM51250550	550	739	7,15
														HM51250600	600	789	7,61
ØD 60 ØAL 50 ØS 25														ØD 60 ØAL 50 ØS 30			
HM52250100	100	310	4,05											HM52300100	100	310	4,25
HM52250150	150	360	4,60											HM52300150	150	360	4,87
HM52250200	200	410	5,14											HM52300200	200	410	5,48
HM52250250	250	460	5,63											HM52300250	250	460	6,11
HM52250300	300	510	6,16											HM52300300	300	510	6,74
HM52250350	350	560	6,69											HM52300350	350	560	7,33
HM52250400	400	610	7,23											HM52300400	400	610	7,96
HM52250450	450	660	7,75											HM52300450	450	660	8,56
HM52250500	500	710	8,26											HM52300500	500	710	9,17
HM52250550	550	760	8,84											HM52300550	550	760	9,79
HM52250600	600	810	9,34											HM52300600	600	810	10,40
HM52250700 NEW!	700	910	10,40											HM52300700	700	910	11,63
HM52250800	800	1010	11,46											HM52300800	800	1010	12,85
HM52251000	1000	1210	13,58											HM52301000	1000	1210	15,31
ØD 70 ØAL 60 ØS 30														ØD 70 ØAL 60 ØS 35			
HM53300100	100	340	6,22											HM53350100	100	340	6,45
HM53300150	150	390	6,89											HM53350150	150	390	7,23
HM53300200	200	440	7,57											HM53350200	200	440	8,00
HM53300250	250	490	8,25											HM53350250	250	490	8,78
HM53300300	300	540	8,92											HM53350300	300	540	9,56
HM53300350	350	590	9,60											HM53350350	350	590	10,33
HM53300400	400	640	10,28											HM53350400	400	640	11,11
HM53300450	450	690	10,95											HM53350450	450	690	11,88
HM53300500	500	740	11,63											HM53350500	500	740	12,66
HM53300550	550	790	12,30											HM53350550	550	790	13,44
HM53300600	600	840	12,97											HM53350600	600	840	14,21
HM53300700 NEW!	700	940	14,33											HM53350700 NEW!	700	940	15,77
HM53300800	800	1040	15,68											HM53350800	800	1040	19,34
HM53301000	1000	1240	18,38											HM53351000	1000	1240	20,42

CILINDRO DOPPIO EFFETTO STANDARD CON ATTACCHI
DOUBLE ACTING CYLINDER WITH ENDS

HM5

Series M250

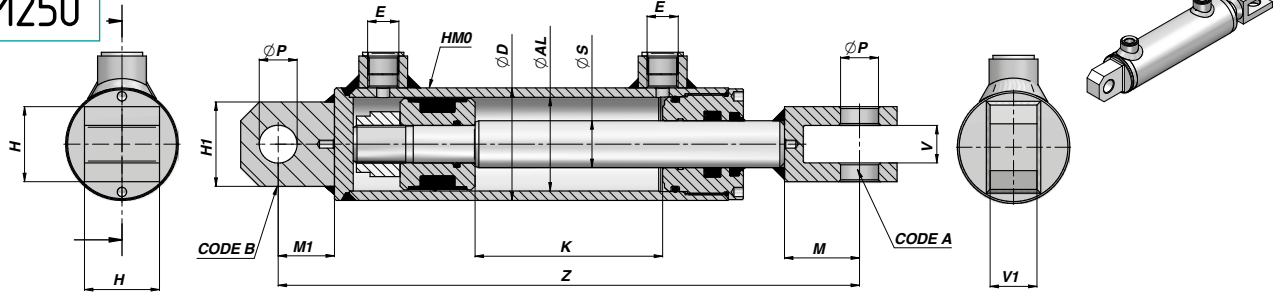

Code	K	Z	kg	E	ØP	H	V	M	H1	V1	M1	Code A	Code B	Code	K	Z	kg	
ØD 70 ØAL 60 ØS 40															ØD 73 ØAL 63 ØS 40			
HM53400200	200	440	8,65											HM5063400200	200	440	8,86	
HM53400250	250	490	9,54											HM5063400250	250	490	9,77	
HM53400300	300	540	10,43											HM5063400300	300	540	10,68	
HM53400350	350	590	11,32											HM5063400350	350	590	11,59	
HM53400400	400	640	12,21											HM5063400400	400	640	12,45	
HM53400450	450	690	13,10											HM5063400450	450	690	13,41	
HM53400500	500	740	13,99	3/8"	25,25	50	25	45	50	30	35	CFS0000025	COF2500000	HM5063400500	500	740	14,31	
HM53400550	550	790	14,88											HM5063400550	550	790	15,22	
HM53400600	600	840	15,77											HM5063400600	600	840	16,16	
HM53400700 NEW!	700	940	17,56											HM5063400700 NEW!	700	940	17,97	
HM53400800	800	1040	19,34											HM5063400800	800	1040	19,79	
HM53401000	1000	1240	22,91											HM5063401000	1000	1240	23,44	
ØD 80 ØAL 70 ØS 35															ØD 80 ØAL 70 ØS 40			
HM54350100	100	340	7,44											HM54400100 NEW!	100	340	7,82	
HM54350150	150	390	8,28											HM54400150 NEW!	150	390	8,77	
HM54350200	200	440	9,11											HM54400200	200	440	9,73	
HM54350250	250	490	9,95											HM54400250	250	490	10,68	
HM54350300	300	540	10,79											HM54400300	300	540	11,63	
HM54350350	350	590	11,63											HM54400350	350	590	12,59	
HM54350400	400	640	12,46	3/8"	25,25	50	25	45	50	30	35	CFS0000025	COF2500000	HM54400400	400	640	13,54	
HM54350450	450	690	13,30											HM54400450	450	690	14,48	
HM54350500	500	740	14,14											HM54400500	500	740	15,44	
HM54350550	550	790	14,98											HM54400550	550	790	16,39	
HM54350600	600	840	15,81											HM54400600	600	840	17,34	
HM54350700 NEW!	700	940	17,49											HM54400700 NEW!	700	940	19,26	
HM54350800	800	1040	19,16											HM54400800	800	1040	21,16	
HM54351000	1000	1240	22,51											HM54401000	1000	1240	24,97	
ØD 92 ØAL 80 ØS 40															ØD 92 ØAL 80 ØS 50			
HM55400200	200	475	13,33											HM55500200	200	475	14,60	
HM55400250	250	525	14,46											HM55500250	250	525	16,00	
HM55400300	300	575	15,58											HM55500300	300	575	17,40	
HM55400400	400	675	17,83											HM55500400	400	675	20,21	
HM55400500	500	775	20,08	1/2"	30,25	60	30	50	60	35	45	CFS0000030	COF3000000	HM55500500	500	775	23,02	
HM55400600	600	875	22,34											HM55500600	600	875	25,82	
HM55400700 NEW!	700	975	24,58											HM55500700 NEW!	700	975	28,62	
HM55400800	800	1075	26,84											HM55500800	800	1075	31,43	
HM55401000	1000	1275	31,34											HM55501000	1000	1275	37,40	
ØD 105 ØAL 90 ØS 50																		
HM5090500300	300	616	23,65															
HM5090500400	400	716	26,98															
HM5090500500	500	816	30,28															
HM5090500600	600	916	33,65															
HM5090500700 NEW!	700	1016	36,98	1/2"	40,25	80	40	70	70	40	60	CF-S0000040	COF4000000					
HM5090500800	800	1116	40,32															
HM5090501000	1000	1316	46,98															
ØD 115 ØAL 100 ØS 50															ØD 115 ØAL 100 ØS 60			
HM56500200	200	540	24,14															
HM56500250	250	590	25,90															
HM56500300	300	640	27,66															
HM56500400	400	740	31,17															
HM56500500	500	840	34,69	1/2"	40,25	80	40	70	70	40	60	CFS0000040	COF4000000	HM56600300	300	640	29,82	
HM56500600	600	940	38,21											HM56600400	400	740	34,02	
HM56500700 NEW!	700	1040	41,73											HM56600500	500	840	38,21	
HM56500800	800	1140	45,24											HM56600600	600	940	42,41	
HM56501000	1000	1340	52,28											HM56600700 NEW!	700	1040	46,61	
														HM56600800	800	1140	50,80	
														HM56601000	1000	1340	59,18	

MATERIALE TUBO: ACCIAIO S1 52.3 DIN 2393 ISO H9
TUBE MATERIAL : STEEL S1 52.3 DIN 2393 ISO H9

MATERIALE ASTA: ACCIAIO UNI C45 SAE 1045 CROMO 25 µm ±5 Rating 9 / 200h ISO 10289 - 1999/ISO 9227-NSS
ROD MATERIAL : STEEL UNI C45 SAE 1045 CHROME 25 µm ±5 Rating 9 / 200h ISO 10289 - 1999/ISO 9227-NSS

CARATTERISTICHE TECNICHE : VEDI PAGINA 36 - TECHNICAL SPECIFICATIONS : SEE PAGE 36