

FZO

Pompa ad Ingranaggi Gear Pump

CODICE DI ORDINAZIONE / ORDERING CODE

200 FZO 015 D S 0

21 UNI 222

ROTAZIONE/ROTATION
D = DESTRO/CLOCKWISE
S = SINISTRO/ANTICLOCKWISE

CILINDRATA/DISPLACEMENT

TIPO/TYPE

POMPA AD INGRANAGGI/GEAR PUMP

UNI
21-222

FZO 15
FZO 22
FZO 27
FZO 36
FZO 43
FZO 57
FZO 65
FZO 90
FZO 110

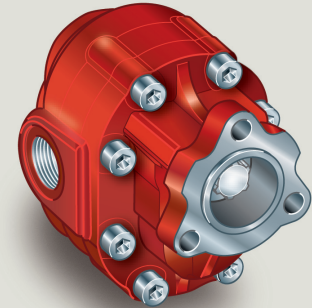

CARATTERISTICHE E DATI TECNICI / SPECIFICATIONS AND TECHNICAL DATA

TIPO TYPE	CODICE CODE	CILINDRATA DISPLACEMENT cm ³ /rev.	A mm	B mm	C ASPIRAZIONE INLET	D MANDATA OUTLET	PESO WEIGHT kg
FZO 15	200FZ0015 D S 0	15	96.5	142.5	3/4" G	1/2" G	8.4
FZO 22	200FZ0022 D S 0	22	99.5	147.5	3/4" G	1/2" G	8.9
FZO 27	200FZ0027 D S 0	27	105	152.5	3/4" G	1/2" G	9
FZO 36	200FZ0036 D S 0	36	101.5	157.5	3/4" G	1/2" G	9.1
FZO 43	200FZ0043 D S 0	43	104.5	162.5	1" G	3/4" G	10.2
FZO 57	200FZ0057 D S 0	57	111.5	172.5	1" G	3/4" G	11.1
FZO 65	200FZ0065 D S 0	65	116.5	177.5	1" G	3/4" G	11.5
FZO 90	200FZ0090 D S 0	84	126	192.5	1" 1/4 G	1" G	12.6
FZO 110	200FZ0110 D S 0	105	138	204.5	1" 1/4 G	1" G	13.7

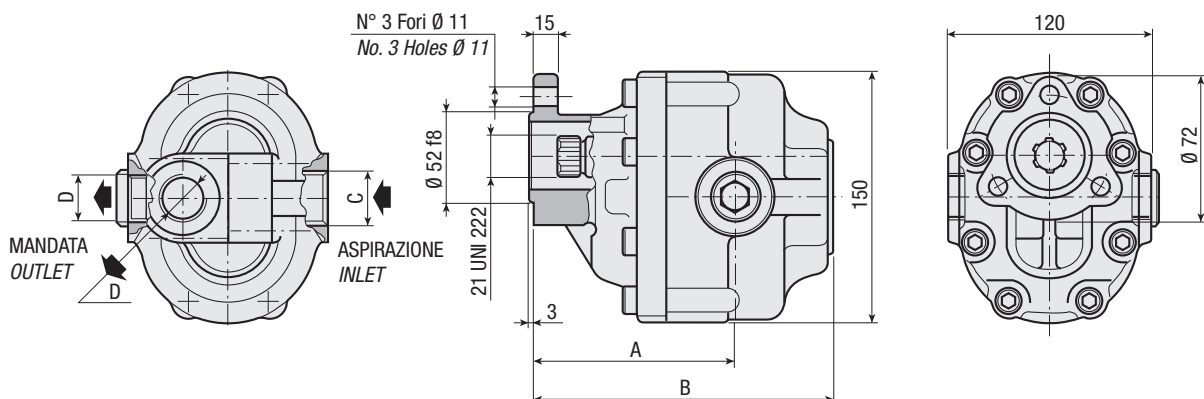

DATI TECNICI / TECHNICAL DATA

ESEMPIO CICLI LAVORO / EXAMPLE OF WORKING CYCLES

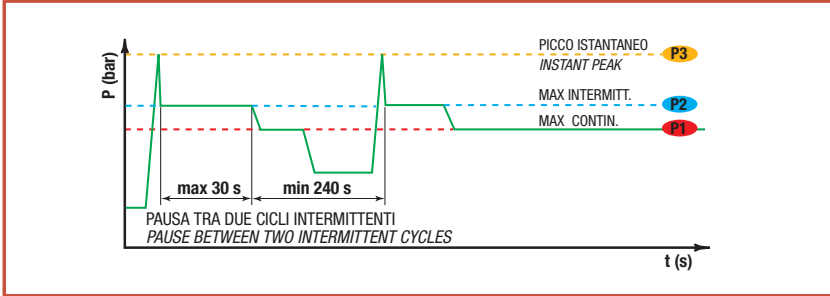

Pressione d'aspirazione: Inlet pressure:	0.7 ÷ 1.5 bar (assoluti/absolute)
Campo viscosità lavoro: Operating viscosity range:	12 ÷ 100 cSt
Temperatura fluido °C (t): Fluid temperature °C (t):	-10° + 80° C

Pressione Lavoro Working Press. P2	Contaminazione / Contamination		Filtro / Filter βx = 75
	NAS 1638	ISO 4406	
≤ 200 bar	12	21/18	40 μm
≥ 200 bar	11	20/17	25 μm

◀ **FILTRAZIONE CONSIGLIATA (ritorno o mandata)**
RECOMMENDED FILTERING (return or outlet)

TIPO / TYPE			FZ015	FZ022	FZ027	FZ036	FZ043	FZ057	FZ065	FZ090	FZ0110
	Vg	cm ³ /n cm ³ /rev.	15	22	27	36	43	57	65	84	105
Cilindrata Displacement											
Pressione massima continua Max continuous operating pressure	P1	bar	315	305	300	300	280	240	220	210	180
Pressione massima intermittente Max intermitt. operat. press. (max 30 s)	P2		340	330	325	325	305	265	240	230	200
Pressione massima di picco Max peak pressure (≤ 0.1 s)	P3		450	450	450	450	400	380	350	300	250
Velocità massima intermittente Max intermittent speed (P ≤ 20 bar)	n3	n/min r.p.m.	4000	4000	3500	3500	3500	3500	3500	3500	3000
Velocità massima continua Max continuous speed (≤ P1)	n1		2500	2500	2200	2200	2200	2000	1800	1500	1500
Velocità minima intermittente Min intermittent speed (≤ P2 x 0.5) (max 30 s)	n4		450	450	350	350	350	300	300	300	300

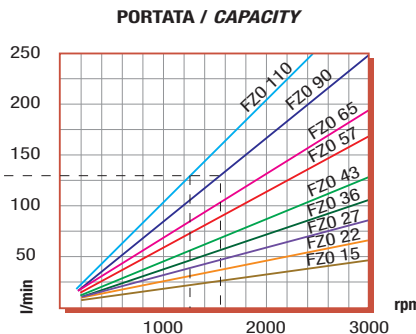
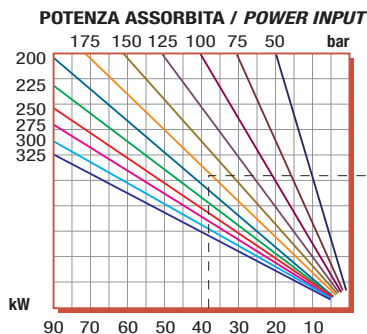

DIAGRAMMI / DIAGRAMS

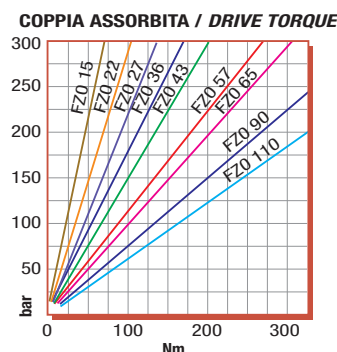
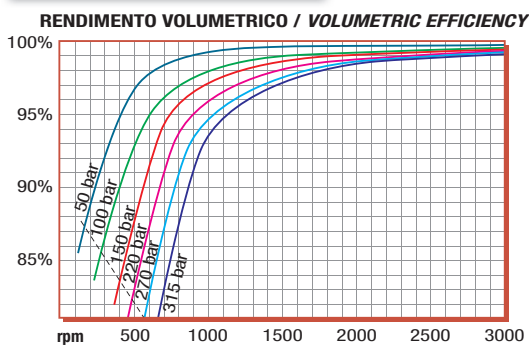

RILIEVI ESEGUITI CON OLIO
ISO VG 46 A 50° C (√= 30 cSt)
THE ABOVE SPECIFICATIONS
REFER TO OIL TYPE ISO
VG 46 AT 50° C (√=30 cSt)